



BEVEL GEARS

STANDARD EXECUTION

page 5

SPECIALE CH EXECUTION

GLEASON SYSTEM

9

SPIRALS

16

SPECIAL PRODUCTIONS

ON REQUEST

19



BEVEL GEARS

BEVEL GEARS

BEVEL GEAR WITH STRAIGHT TEETH
SPECIAL CH EXECUTION
GLEASON SYSTEM



SPIRALS BEVEL GEARS



BEVEL GEAR WITH STRAIGHT TEETH
STANDARD EXECUTION



SPIRALS BEVEL GEARS
GLEASON SYSTEM



The range of bevel gear showed in the catalogue is a selection structured according to transmission module and ratio, which is designed to meet the needs of general plant engineering and general mechanics to transmit motion among concurrent axes.

As such the range does not claim to guarantee particularly heavyduty performance or to cater for ratio ranges that extend to cover every need.

The external configuration of the bevel gear complies with the sizing criteria as established by the

DIN 3971 Standards,

while the tooth geometry, corrected by displacing the profiles and by varying the taper, is a specific solution exclusive to CHIARAVALLI GROUP SpA.

This solution, provides special advantages since:

- the coupling conditions between the pinion and the ring gear are improved;
- a smoother motion transmission is assured;
- tooth resistance is increased;
- the undercut effect on the pinion is avoided, even in the case of high transmission ratios and pinions with a limited number of teeth.

Since these refer to a selection of gears intended to be used in a broad range of applications, CHIARAVALLI GROUP SpA, continuing a tradition that has now become firmly established, has defined a standardised tolerance category for the processing of the Company's range of bevel gear, which means that there is a controlled gearing gap between the wheels.

The requirements detailed in the

DIN 3967 Standards

adapted to the virtual teeth profile of the bevel gear and the recommendations of the

DIN 3964 Standards

to calculate the corresponding axial displacements for the assembly distances have been used for this purpose.

We are therefore in a position to provide the end user precise information regarding the tolerances to be adopted to define shaving adjustments to a given clearance, in accordance with the values detailed in the dimensional tables.

All the bevel gears manufactured by CHIARAVALLI GROUP SpA will be produced in accordance with the profile envelope procedure on modern gear cutting machines, which enables CHIARAVALLI GROUP SpA to ensure a satisfactory quality level thanks to the systematic checking of processing tolerances.

For this technological sector too, the equipment and the range of machines available to CHIARAVALLI GROUP SpA enables the Company to produce bevel gears based on a drawing and in accordance with the Customer's specifications.





BEVEL GEARS WITH STRAIGHT TEETH

BEVEL GEARS WITH STRAIGHT TEETH





BEVEL GEAR WITH STRAIGHT TEETH norm DIN 3967

5

RATIO 1:1

Pressure angle: 20°
with normal axes in compliance to
UNI 6588

Teeth according to DIN 3967

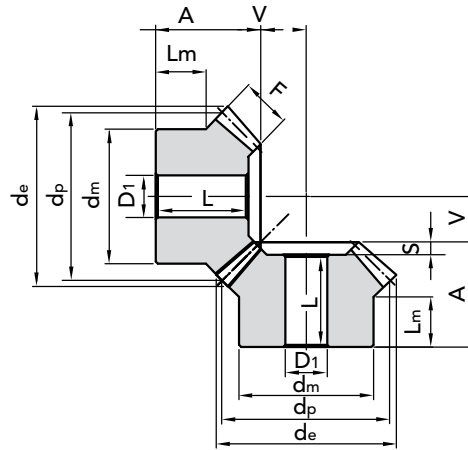

M	Z	PART NUMBER	d_p	d_e	F	A	d_m	D_1	L	V	S	L_m	Kg
1.5	16	35151116	24,0	26,12	6	18,9	20,3	8	-	7,10	-	12	0,03
	20	32151120	30,0	32,12	10	20	22	10	18	7,40	2	8,5	0,05
	25	32151125	37,5	39,62	10	23	28	10	21	11,09	2	12	0,10
	30	32151130	45,0	47,12	12	25	30	12	22,5	13,35	2,5	12	0,15
2	16	35201116	32,0	34,83	8	23,5	25,3	8	-	9,50	-	14	0,06
	20	32201120	40,0	42,83	12	25	32	10	22	10,78	3	11,7	0,14
	25	32201125	50,0	52,82	14	28	40	12	25	14,28	3	12,3	0,25
	30	32201130	60,0	62,83	16	30	50	12	27	17,78	3	12,8	0,41
2.5	16	35251116	40,0	43,53	10	28,1	30,3	12	-	11,90	-	15	0,13
	20	32251120	50,0	53,53	12	30,5	40	12	27	15,43	3,5	16	0,27
	25	32251125	62,5	66	15	33,5	50	15	30	19,48	3,5	16	0,47
	30	32251130	75,0	78,53	18	35,5	55	15	32	23,63	3,5	16	0,69
3	16	35301116	48,0	52,25	12	31,7	40,3	12	-	14,30	-	18	0,24
	20	32301120	60,0	64,24	18	35	45	15	31	16,00	4	13,6	0,41
	25	32301125	75,0	79,24	20	38	55	15	34	22,00	4	16	0,72
	30	32301130	90,0	94,24	22	40	60	20	36	28,00	4	17	0,99
3.5	16	35351116	56,0	60,95	14	36,4	45,3	16	-	16,60	-	20	0,38
	20	32351120	70,0	74,95	22	40,5	55	15	36	18,13	4,5	16,1	0,68
	25	32351125	87,5	92,45	26	43,5	65	20	39	23,97	4,5	18	1,10
	30	32351130	105,0	109,95	30	48	70	20	43,5	30,02	4,5	19	1,61
4	16	35401116	64,0	69,65	15	44,3	50,3	16	-	19,70	-	25	0,52
	20	32401120	80,0	85,65	25	43	60	18	38	20,74	5	18	0,90
	25	32401125	100,0	105,65	28	45	70	20	40	28,50	5	18	1,45
	30	32401130	120,0	125,65	32	48	80	20	43	35,67	5	16	2,66
4.5	16	35451116	72,0	78,38	17,5	46,3	55,3	20	-	21,70	-	25	0,73
	20	32451120	90,0	96,38	28	48	65	20	42	23,41	6	18	1,25
	25	32451125	112,5	118,8	32	50	75	20	44	31,76	6	18	2,04
	30	32451130	135,0	141,38	35	53	90	20	47	40,82	6	17	3,24
5	16	35501116	80,0	87,07	18	48,9	60,3	20	-	25,10	-	25	0,94
	20	32501120	100,0	107,07	30	50,5	70	20	44	26,86	6,5	18,5	1,61
	25	32501125	125,0	132,07	34	53,5	90	20	47	36,36	6,5	18	2,94
	30	32501130	150,0	157,07	38	56,5	110	20	50	45,97	6,5	18	4,46

BEVEL GEAR WITH STRAIGHT TEETH RATIO 1:1

6

MATERIAL C 45 UNI 7847



CAD drawings available on our site
www.chiaravalli.com

Quantity, availability and prices
on B2B Chiaravalli



RATIO 1:2

Pressure angle: 20°
with normal axes in compliance to
UNI 6588

Teeth according to DIN 3967

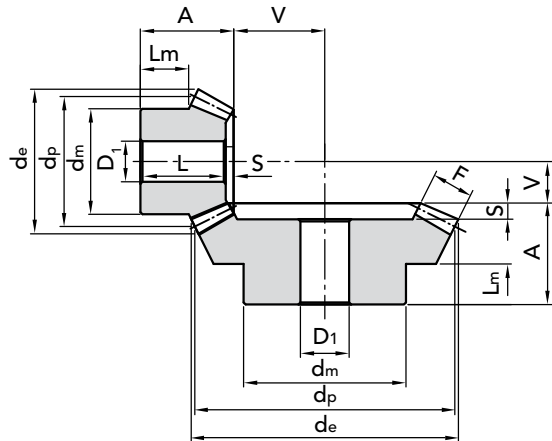

M	Z	PART NUMBER	d_p	d_e	F	A	d_m	D_1	L	V	S	L_m	Kg
1,5	16	32151216	24,0	26,68	8	19,5	21	10	18	16,33	1,5	11,3	0,04
	32	33151232	48,0	49,34	8	20	32	12	17	7,45	3	10	0,14
2	16	32201216	32,0	35,57	10	23	26	10	21	22,41	2	11,9	0,09
	32	33201232	64,0	65,78	10	25	40	12	21	10,21	4	10	0,14
2,5	16	32251216	40,0	44,47	12	27,5	34	12	25	28,38	2,5	14,4	0,16
	32	33251232	80,0	82,23	12	25	50	15	20	12,97	5	10	0,59
3	16	32301216	48,0	53,36	15	28	40	15	25	33,64	3	11,6	0,23
	32	33301232	96,0	98,68	15	30	60	15	24	15,31	6	10	1,05
3,5	16	32351216	56,0	62,26	18	33,5	48	15	30	38,83	3,5	14,4	0,40
	32	33351232	112,0	115,12	18	31	70	20	24	17,77	7	10	1,57
4	16	32401216	64,0	71,15	20	36	50	15	32	44,81	4	13,4	0,49
	32	33401232	128,0	131,57	20	32	80	20	24	20,42	8	10	2,29
4,5	16	32451216	72,0	80,05	22	39,5	60	20	35	51,00	4,5	15,4	0,75
	32	33451232	144,0	148	22	36	90	20	27	23,21	9	10	2,99
5	16	32501216	80,0	88,94	25	50	60	20	45	56,06	5	21,1	1,07
	32	33501232	160,0	164,46	25	38	100	20	28	25,52	10	10	3,95

MATERIAL **C 45 UNI 7847**

CAD drawings available on our site
www.chiaravalli.com

Quantity, availability and prices
on B2B Chiaravalli





BEVEL GEAR WITH STRAIGHT TEETH norm DIN 3967

7

RATIO 1:3

Pressure angle: 20°
with normal axes in compliance to
UNI 6588

Teeth according to DIN 3967

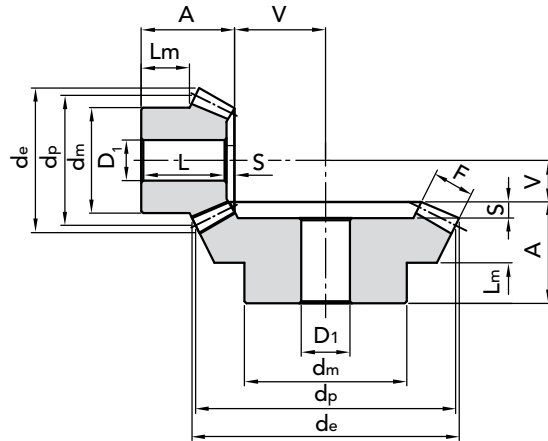

M	Z	PART NUMBER	d_p	d_e	F	A	d_m	D_1	L	V	S	L_m	Kg
1,5	16	32151316	24,0	26,82	12	24	20	10	23	24,32	1	11,7	0,04
	48	33151348	72,0	72,95	12	20	50	12	17	7,27	3	10	0,31
2	16	32201316	32,0	35,8	15	28,5	26	12	27	33,26	1,5	12,4	0,08
	48	33201348	96,0	97,26	15	23	60	15	19	9,90	4	10	0,67
2,5	16	32251316	40,0	44,74	18	32	32	12	30	42,41	1,5	13	0,15
	48	33251348	120,0	121,58	18	26	70	20	21	12,60	5	10	1,22
3	16	32301316	48,0	53,69	18	32	40	15	30	54,25	2	12,1	0,27
	48	33301348	144,0	145,9	18	29	80	20	23	16,20	6	10	2,01
3,5	16	32351316	56,0	62,64	22	38	48	15	35,5	62,29	2,5	15	0,45
	48	33351348	168,0	170,21	22	31	90	20	24	18,48	7	10	3,08
4	16	32401316	64,0	71,59	25	41,5	55	20	38,5	71,23	3	15,2	0,67
	48	33401348	192,0	194,53	25	33	100	20	25	21,20	8	10	4,40
4,5	16	32451316	72,0	80,53	28	53	60	20	50	80,27	3	23,4	1,05
	48	33451348	216,0	218,84	28	49	100	20	40	23,93	9	18	7,23
5	16	32501316	80,0	89,48	35	60	60	20	57	85,61	3	22,5	1,38
	48	33501348	240,0	243,16	35	50	150	20	40	25,45	10	20	8,72

BEVEL GEAR WITH STRAIGHT TEETH RATIO 1:3

6

MATERIAL C 45 UNI 7847

CAD drawings available on our site
www.chiaravalli.com

Quantity, availability and prices
on B2B Chiaravalli





RATIO 1:4

Pressure angle: 20°
with normal axes in compliance to
UNI 6588

Teeth according to DIN 3967

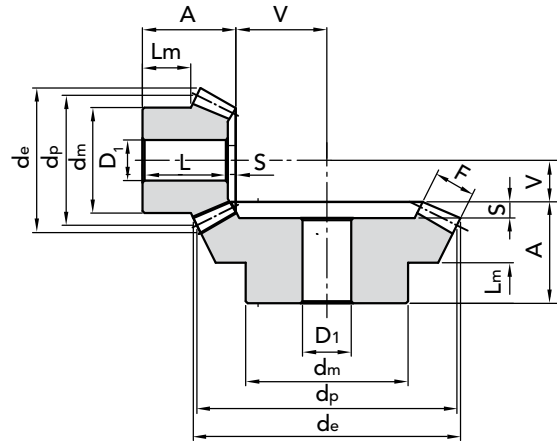

M	Z	PART NUMBER	d_p	d_e	F	A	d_m	D_1	L	V	S	L_m	Kg
1,5	16	32151416	24,0	26,91	12	25	18	10	24	36,09	1	12,2	0,04
	64	33151464	96,0	96,73	12	22	70	15	19	8	3	10	0,75
2	16	32201416	32,0	35,88	15	24	25	12	23	49	1	8,2	0,08
	64	33201464	128,0	128,97	15	24	80	20	20	10,88	4	10	1,35
2,5	16	32251416	40,0	44,85	18	30,5	30	12	29	62,07	1,5	11,7	0,18
	64	33251464	160,0	161,21	18	29	90	20	24	13,74	5	10	2,70
3	16	32301416	48,0	53,82	22	34	40	15	32	74,10	2	11	0,29
	64	33301464	192,0	193,45	22	30	100	20	24	16,41	6	10	4,12
3,5	16	32351416	56,0	62,8	25	45	48	15	43	87,10	2	19,1	0,48
	64	33351464	224,0	225,7	25	50	100	20	43	19,28	7	22	7,53
4	16	32401416	64,0	71,76	30	50	50	20	48	98,17	2	18,5	0,75
	64	33401464	256,0	257,94	30	50	120	20	42	21,76	8	20	10,66
4,5	16	32451416	72,0	80,73	32	53	55	20	50,5	112,08	2,5	19	1,12
	64	33451464	288,0	290,18	32	53	130	20	44	24,83	9	23	13,8
5	16	32501416	80,0	89,7	35	58	60	20	55,5	125,12	2,5	20,6	1,54
	64	33501464	320,0	322,42	35	58	150	20	48	27,73	10	25	15,6

MATERIAL **C 45 UNI 7847**

CAD drawings available on our site
www.chiaravalli.com

Quantity, availability and prices
on B2B Chiaravalli





BEVEL GEAR WITH STRAIGHT TEETH SPECIAL CH EXECUTION GLEASON SYSTEM

RATIO 1:1

Normal axis

Pressure angle: 20°

GLEASON SYSTEM

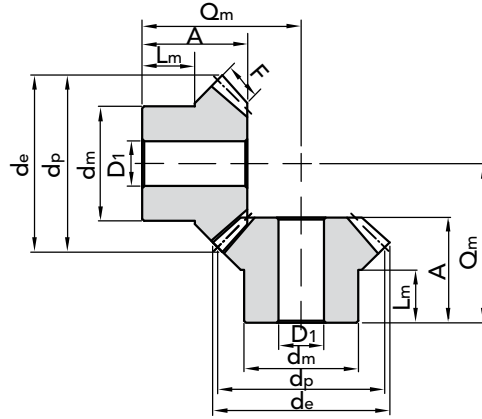

M	Z	PART NUMBER	dp	de	F	A	dm	D1	V	Lm	Kg
1	16	35101116	16	17,4	4	11,2	13,3	4	4,8	6,5	0,02
	19	35101119	19	20,4	4	11,8	15,3	4	6,2	6,5	0,02
	22	35101122	22	23,4	4,7	12,8	16,3	5	7,2	6,5	0,02
	26	35101126	26	27,4	5,5	13,3	20,3	5	8,7	7	0,04
	30	35101130	30	31,4	6,4	16	20,3	5	10	8	0,05
1,5	16	35151116	24	26,1	6	18,9	20,3	8	7,1	12	0,04
	19	35151119	28,5	30,6	7	21,3	20,3	8	8,7	12	0,05
	22	35151122	33	35,1	7,5	22,5	25,3	8	10,5	12	0,09
	26	35151126	39	41,1	8,5	23,2	28,3	8	12,8	12	0,12
	30	35151130	45	47,1	10	27,2	30,3	12	14,8	12	0,17
2	16	35201116	32	34,8	8	23,5	25,3	8	9,5	14	0,08
	19	35201119	38	40,8	9	24,2	25,3	8	11,8	12	0,11
	22	35201122	44	46,8	10	27,9	30,3	12	14,1	14	0,18
	26	35201126	52	54,8	12	31,4	35,3	12	16,6	14	0,28
	30	35201130	60	62,8	13	34,1	40,3	14	19,9	17	0,41
2,5	16	35251116	40	43,5	10	28,1	30,3	12	11,9	15	0,14
	19	35251119	47,5	51	11	27,1	35,3	12	14,9	13	0,21
	22	35251122	55	58,5	12	30,1	45,3	16	17,9	16	0,36
	26	35251126	65	68,5	15	33,2	45,3	16	20,8	16	0,47
	30	35251130	75	78,5	16	39	50,3	16	25	20	0,74
3	16	35301116	48	52,5	12	31,7	40,3	12	14,3	18	0,28
	19	35301119	57	61,2	13	36	40,3	14	18	17	0,39
	22	35301122	66	70,2	15	36,9	50,3	16	21,1	17	0,59
	26	35301126	78	82,2	17	38,4	50,3	16	25,6	18	0,77
	30	35301130	90	94,2	19	43,8	60,3	20	30,2	22	1,19
3,5	16	35351116	56	60,9	14	36,4	45,3	16	16,6	20	0,41
	19	35351119	66,5	71,5	15	37,8	50,3	18	21	19	0,59
	22	35351122	77	81,9	17	39,1	55,3	20	24,9	18	0,84
	26	35351126	91	96	20	43,35	62,3	20	29,7	20	1,17
	30	35351130	105	110	23	47,1	70,3	20	34,9	22	1,69
4	16	35401116	64	69,7	15	44,3	50,3	16	19,7	25	0,66
	19	35401119	76	81,7	18	44,4	55,3	20	23,6	22	0,88
	22	35401122	88	93,7	20	45,9	60,3	20	28,1	22	1,21
	26	35401126	104	109,7	23	48	70,3	20	34	22	1,68
	30	35401130	120	125,7	26	54,2	80,3	20	39,8	25	2,50
4,5	16	35451116	72	78,4	17,5	46,3	55,3	20	21,7	25	0,84
	19	35451119	85,5	91,8	20	49	62,3	20	26,57	25	1,15
	22	35451122	99	105,3	22	50,1	70,3	20	31,9	25	1,72
	26	35451126	117	123	25	54,7	75,3	20	38,6	26	2,22
	30	35451130	135	141,4	29	60	80,3	20	45	28	3,25
5	16	35501116	80	87,1	18	48,9	60,3	20	25,1	25	1,10
	19	35501119	95	102,1	22	52,2	60,3	20	29,8	25	1,50
	22	35501122	110	117,1	24	58,2	80,3	20	35,8	30	2,39
	26	35501126	130	137,1	29	62,7	80,3	20	42,3	30	3,27
	30	35501130	150	157,1	32	68,9	80,3	20	50,1	35	4,13

BEVEL GEAR WITH STRAIGHT TEETH SPECIAL CH EXECUTION RATIO 1:1

MATERIAL **C 45 UNI 7847**



CAD drawings available on our site
www.chiaravalli.com

Quantity, availability and prices
on B2B Chiaravalli

BEVEL GEAR WITH STRAIGHT TEETH SPECIAL CH EXECUTION GLEASON SYSTEM

BEVEL GEAR WITH STRAIGHT TEETH SPECIAL CH EXECUTION RATIO 1:1.5
RATIO 1:1.5

Normal axis

Pressure angle: 20°

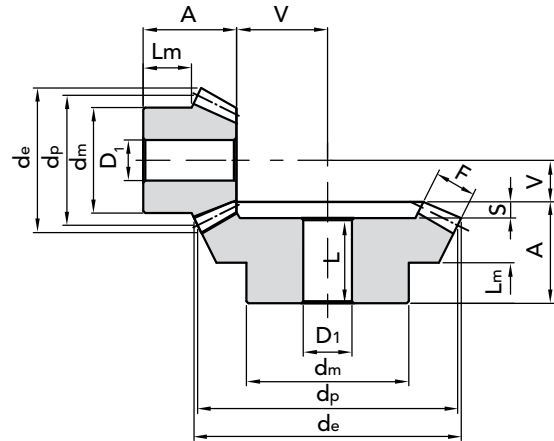
GLEASON SYSTEM

M	Z	PART NUMBER	d_p	d_e	F	A	d_m	D_1	L	V	S	L_m	Kg
1	16	35101516	16	18,1	4,3	12	13,3	4		8		7	0,04
	24	36101524	24	24,8	4,3	14,8	20,3	5	13,3	5,2	1,5	9,3	0,05
1,5	16	35151516	24	27,1	8	20,3	20,3	8		10,7		11,8	0,04
	24	36151524	36	37,2	8	24,9	28,3	8	22,7	7,1	2,2	16	0,04
2	16	35201516	32	36,2	10	25,2	25,3	8		14,8		13,8	0,08
	24	36201524	48	49,7	10	27,2	32,3	8	24,7	9,8	2,5	16	0,32
2,5	16	35251516	40	45,2	13	30,8	32,3	12		18,2		16,4	0,14
	24	36251524	60	62,1	13	34	45,3	14	30,8	12	3,2	20	0,50
3	16	35301516	48	54,3	14,5	32,4	40,3	12		22,6		16,4	0,28
	24	36301524	72	74,5	14,5	36,2	55,3	16	32	14,8	4,2	20	0,96
3,5	16	35351516	56	63,3	18	40,4	45,3	16		25,6		20,4	0,41
	24	36351524	84	86,9	18	44,2	55,3	20	40	16,8	4,2	25	1,30
4	16	35401516	64	72,4	18	46,8	50,3	16		31,2		25,4	0,66
	24	36401524	96	99,3	18	45,5	60,3	20	40	20,5	5,5	25	2,50
4,5	16	35451516	72	81,4	20	47,6	60,3	20		35,4		25,1	0,84
	24	36451524	108	111,7	20	57,8	80,3	20	51,3	23,2	6,5	35	2,90
5	16	35501516	80	90,5	24	54,1	60,3	20		37,9		25,4	1,10
	24	36501524	120	124,1	24	61,1	80,3	20	54,5	24,9	6,6	35	3,50

MATERIAL C 45 UNI 7847

 CAD drawings available on our site
www.chiaravalli.com

 Quantity, availability and prices
 on B2B Chiaravalli





BEVEL GEAR WITH STRAIGHT TEETH SPECIAL CH EXECUTION GLEASON SYSTEM

RATIO 1:2

Normal axis
Pressure angle: 20°

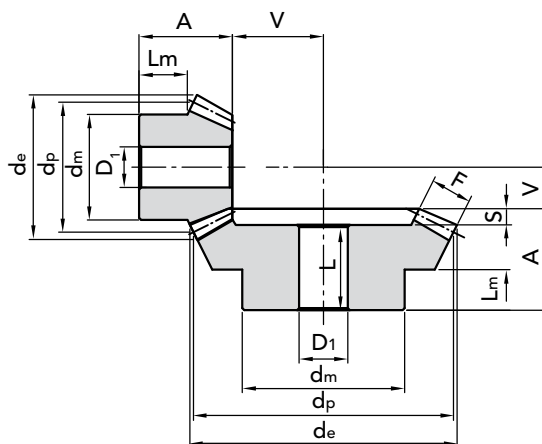
GLEASON SYSTEM



M	Z	PART NUMBER	d_p	d_e	F	A	d_m	D_1	L	V	S	L_m	Kg
1	15	35101215	15	17,4	5	11,9	13,3	4		10,1		6,5	0,03
	30	36101230	30	30,6	5	15,1	20,3	5	13,7	4,9	1,4	9	0,06
1.5	15	35151215	22,5	26,1	9	21,1	19,3	8		13,9		11,9	0,04
	30	36151230	45	45,9	9	25,2	32,3	8	23	6,8	2,2	16	0,19
2	15	35201215	30	34,8	11,5	26	25,3	8		19		14,1	0,09
	30	36201230	60	61,2	11,5	29,8	40,3	14	26,8	9,2	3	18	0,32
2.5	15	35251215	37,5	43,5	15	31,8	32,3	12		23,2		16,2	0,17
	30	36251230	75	76,5	15	33,7	45,3	16	30	11,3	3,7	20	0,57
3	15	35301215	45	52,2	17	37,3	40,3	12		28,7		19,9	0,25
	30	36301230	90	91,8	17	42,1	55,3	16	38	13,9	4,1	25	1,03
3.5	15	35351215	52,5	60,9	20,5	46,1	45,3	16		32,9		24,7	0,42
	30	36351230	105	107,1	20,5	45	60,3	20	40	16	5	25	1,51
4	15	35401215	60	69,6	22,5	48,6	50,3	20		38,4		24,6	0,52
	30	36401230	120	122,3	22,5	57,3	80,3	20	51,9	18,7	5,4	35	2,21
4.5	15	35451215	67,5	78,3	26	51,4	60,3	20		42,6		24,7	0,8
	30	36451230	135	137,6	26	60,3	80,3	20	54,3	20,7	6	35	2,88
5	15	35501215	75	87	30	57,6	60,3	20		46,4		25,3	1,16
	30	36501230	150	152,9	30	62,5	80,3	20	56	22,5	6,5	35	2,79

BEVEL GEAR WITH STRAIGHT TEETH SPECIAL CH EXECUTION RATIO 1:2

MATERIAL **C 45 UNI 7847**



CAD drawings available on our site
www.chiaravalli.com

Quantity, availability and prices
on B2B Chiaravalli

BEVEL GEAR WITH STRAIGHT TEETH SPECIAL CH EXECUTION GLEASON SYSTEM

BEVEL GEAR WITH STRAIGHT TEETH SPECIAL CH EXECUTION RATIO 1:2.5

RELATION 1:2.5

Normal axis
Pressure angle: 20°

GLEASON SYSTEM

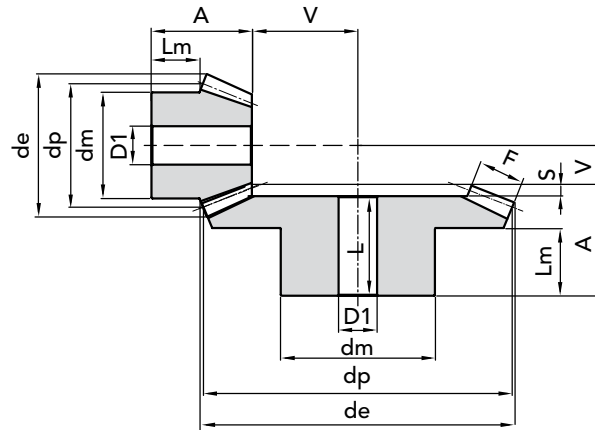

M	Z	PART NUMBER	d_p	d_e	F	A	d_m	D_1	L	V	S	L_m	Kg
1	16	35102516	16	18,6	6,5	14,4	13,3	4		13,6		7,4	0,04
	40	36102540	40	40,4	6,5	14,8	25,3	8	13	5,2	1,8	9	0,09
1.5	16	35152516	24	27,9	11,5	24,2	20,3	8		18,8		12,3	0,04
	40	36152540	60	60,7	11,5	27,8	40,3	14	25,5	7,2	2,3	18	0,17
2	16	35202516	32	37,2	15	29,6	25,3	8		25,4		13,7	0,04
	40	36202540	80	80,9	15	32,4	45,3	16	29	9,6	3,4	20	0,15
2.5	16	35252516	40	46,4	19	38,4	32,3	12		31,6		18,5	0,17
	40	36252540	100	101,1	19	39,8	55,3	16	35,9	12,2	3,9	25	1,23
3	16	35302516	48	55,7	21,5	41,9	40,3	16		39,1		19,6	0,33
	40	36302540	120	121,4	21,5	47,9	60,3	20	44	15,1	3,9	30	1,83
3.5	16	35352516	56	65	22,6	49,1	45,3	20		47,9		25	0,33
	40	36352540	140	141,6	22,6	54,6	80,3	20	50	18,4	4,6	35	1,90
4	16	35402516	64	74,3	26	52,5	55,3	20		54,5		25,3	0,65
	40	36402540	170	161,8	26	57,0	80,3	20	50,5	21	6,5	35	2,53
4.5	16	35452516	72	83,6	30	56,3	60,3	20		60,7		24,6	0,97
	40	36452540	180	182,1	30	59,7	80,3	20	53	23,3	6,7	35	5,30
5	16	35502516	80	92,9	32	65,4	60,3	20		68,6		30,1	1,23
	40	36502540	200	202,3	32	65,7	90,3	20	58,3	26,3	7,4	40	7,20

MATERIAL **C 45 UNI 7847**

CAD drawings available on our site
www.chiaravalli.com

Quantity, availability and prices
on B2B Chiaravalli





BEVEL GEAR WITH STRAIGHT TEETH SPECIAL CH EXECUTION GLEASON SYSTEM

13

RELATION 1:3

Normal axis
Pressure angle: 20°

GLEASON SYSTEM

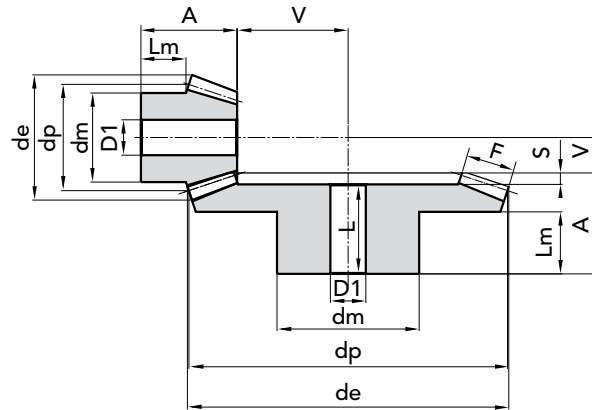

M	Z	PART NUMBER	d_p	d_e	F	A	d_m	D_1	L	V	S	L_m	Kg
1	15	35101315	15	17,7	7,1	16,6	13,3	4		15,4		9,2	0,03
	45	36101345	45	45,3	7,1	17,1	25,3	8	15,2	4,9	1,9	10	0,09
1.5	15	35151315	22,5	26,5	10,5	22,6	19,3	8		23,4		11,7	0,04
	45	36151345	67,5	68,1	10,5	29,6	45,3	14	27,2	7,4	2,4	20	0,40
2	15	35201315	30	35,4	14	28,9	25,3	8		31,1		14,2	0,09
	45	36201345	90	90,8	14	32,1	45,3	16	28,4	9,9	3,7	20	0,62
2.5	15	35251315	37,5	44,2	18	34,6	32,3	12		38,4		15,9	0,17
	45	36251345	112,5	113,4	18	39,7	60,3	20	35,3	12,3	4,4	25	1,19
3	15	35301315	45	53	21	41,3	40,3	16		46,7		19,7	0,29
	45	36301345	135	136,1	21	47,2	60,3	20	42	14,8	5,2	30	1,91
3.5	15	35351315	52,5	61,9	23,5	49,6	45,3	20		55,4		25	0,48
	45	36351345	157,5	158,8	23,5	54,4	80,3	20	48,6	17,6	5,8	35	2,21
4	15	35401315	60	70,7	27,5	54,3	50,3	20		62,7		25,4	0,70
	45	36401345	180	181,5	27,5	57	80,3	20	50,5	20	6,5	35	4,21
4.5	15	35451315	67,5	79,5	28,5	55,2	55,3	20		72,8		24,8	1,14
	45	36451345	202,5	204,2	28,5	63,9	90,3	20	57	23,1	6,9	40	7,03
5	15	35501315	75	88,4	33	65,3	60,3	20		79,7		30	1,45
	45	36501345	225	226,9	33	66,7	90,3	20	59,2	25,3	7,5	40	8,42

BEVEL GEAR WITH STRAIGHT TEETH SPECIAL CH EXECUTION RATIO 1:3

6

MATERIAL C 45 UNI 7847

CAD drawings available on our site
www.chiaravalli.com

Quantity, availability and prices
on B2B Chiaravalli



BEVEL GEAR WITH STRAIGHT TEETH SPECIAL CH EXECUTION GLEASON SYSTEM

BEVEL GEAR WITH STRAIGHT TEETH SPECIAL CH EXECUTION RATIO 1:3.5

RATIO 1:3.5

Normal axis
Pressure angle: 20°

GLEASON SYSTEM

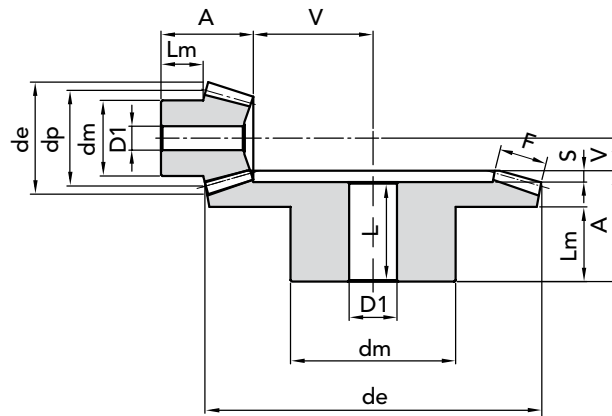

M	Z	PART NUMBER	d_p	d_e	F	A	d_m	D_1	L	V	S	L_m	Kg
1.5	16	35153516	24	28,1	12	24,0	20,3	8		30		11,5	0,05
	56	36153556	84	84,5	12	34,8	45,3	14	32	8,2	2,8	25	0,63
2	16	35203516	32	37,5	16	30,9	25,3	8		40,1		14,1	0,09
	56	36203556	112	112,6	16	37,1	55,3	16	33,3	10,9	3,8	25	1,30
2.5	16	35253516	40	46,8	20	38,9	32,3	14		50,1		17,9	0,20
	56	36253556	140	140,8	20	44,4	60,3	20	40	13,6	4,4	30	2,59
3	16	35303516	48	56,2	24	49,9	40,3	16		60,1		24,9	0,31
	56	36303556	168	169	24	52,7	80,3	20	47,5	16,3	5,2	35	3,94
3.5	16	35353516	56	65,6	25	52,0	45,5	20		73		25,5	0,62
	56	36353556	196	197,1	25	55,1	80,3	20	49,1	19,9	6,0	35	5,60

MATERIAL **C 45 UNI 7847**

CAD drawings available on our site
www.chiaravalli.com

Quantity, availability and prices
on B2B Chiaravalli





BEVEL GEAR WITH STRAIGHT TEETH SPECIAL CH EXECUTION GLEASON SYSTEM

15

RATIO 1:4

Normal axis
Pressure angle: 20°

GLEASON SYSTEM

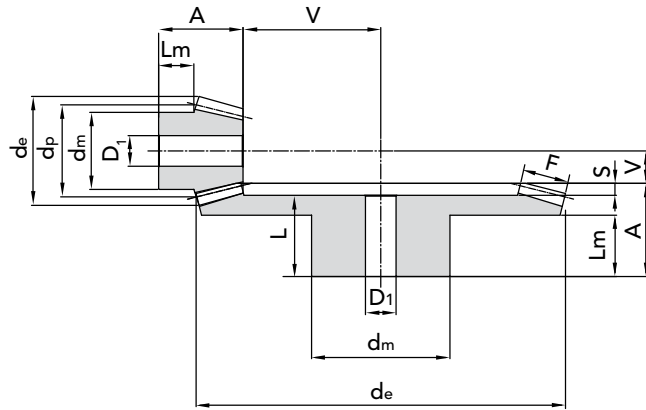

M	Z	PART NUMBER	d_p	d_e	F	A	d_m	D_1	L	V	S	L_m	Kg
1	15	35101415	15	17,8	9,3	17,2	13,3	4		20,8		7,7	0,03
	60	36101460	60	60,3	9,3	17,1	30,3	8	15,2	4,9	1,9	10	0,15
1,5	15	35151415	22,5	26,7	11	23	20,3	8		34		11,7	0,05
	60	36151460	90	90,4	11	34	50,3	16	31,2	8	2,8	25	0,60
2	15	35201415	30	35,6	16	31	25,3	8		44		14,4	0,09
	60	36201460	120	120,6	16	37,6	60,3	16	34,2	10,4	3,4	25	1,30
2,5	15	35251415	37,5	44,5	19	38,1	32,3	14		55,9		18,4	0,20
	60	36251460	150	150,7	19	44,8	60,3	20	40	13,2	4,8	30	2,59
3	15	35301415	45	53,3	23	48,1	40,3	16		66,9		24,5	0,31
	60	36301460	180	180,8	23	53,2	80,3	20	48,2	15,8	5	35	3,94
3,5	15	35351415	52,5	62,2	26	52,1	45,3	20		78,9		25,1	0,60
	60	36351460	210	211	26	60,4	90,3	20	54,4	18,6	6	40	5,62
4	15	35401415	60	71,1	30	55,1	50,3	20		89,9		23	0,81
	60	36401460	240	241,1	30	60,8	90,3	20	53	21,2	7,8	40	6,43
4,5	15	35451415	67,5	79,97	32	57	52,3	20		102,9		23	1,15
	60	36451460	270	271,24	32	62	90,3	20	53,5	24,3	8,5	40	11,35
5	15	35501415	75	88,8	34	62	55,3	20		115,7		25	1,80
	60	36501460	300	301,3	34	65	90,3	20	55	27	10	40	14,45

BEVEL GEAR WITH STRAIGHT TEETH SPECIAL CH EXECUTION RATIO 1:4

6

MATERIAL **C 45 UNI 7847**



CAD drawings available on our site
www.chiaravalli.com

Quantity, availability and prices
on B2B Chiaravalli